

KLP® SLITCOILCARRIER

For safe storage of your (slit)coils

An innovative alternative for the transport of slit coils 'eye-to-the-sky': in close co-operation with several European steel service centres, Lankhorst Mouldings have developed a one-piece plastic 'Slitcoilcarrier'. Many European service centres are constantly searching for cost savings in their logistics.

When pallets are used in a return-system, these costs can easily be reduced by implementing our KLP® Slitcoilcarriers: after a few return-trips it will be cost saving. Besides the logistical advantages, the KLP® Slitcoilcarriers also offers the well known advantages of plastic: less damage, less corrosion, improved safety.

type	diameter coils (mm)	maximum load (tons)	weight (kg)
type A	900-1250	15	21
type B	700-1700	15	25

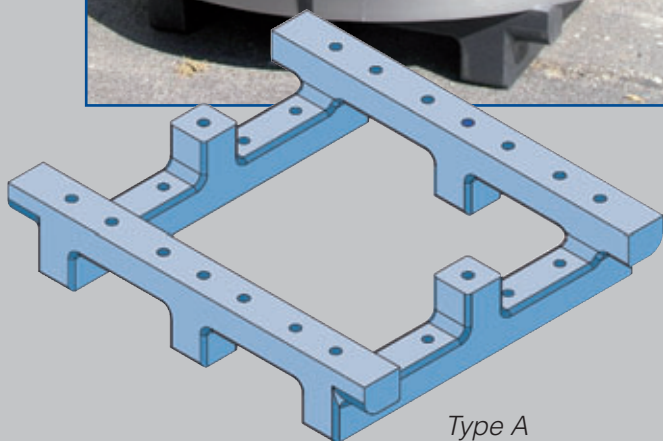

Type A

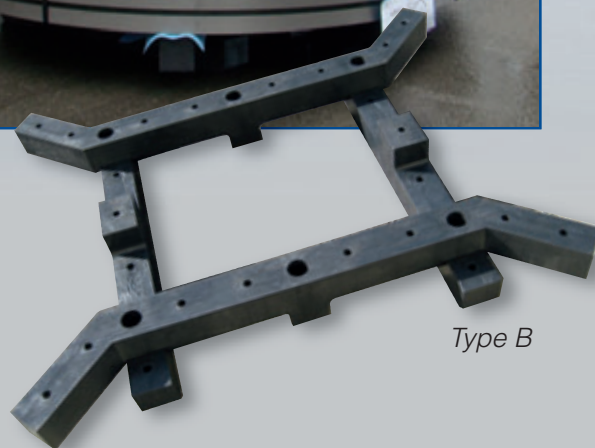

Type B

Advantages of KLP® Slitcoilcarriers are:

- A pallet in-one-piece without nails (type A)
- Wide range of coil diameters
- Load bearing capacity 15 tons
- Wide and high fork lift entries
- Improved safety during handling
- No splinters – less damage
- No moisture – no corrosion
- Larger bearing surface – less damage
- Cost saving through a long lifetime

KLP® COILCARRIERS

Reusable heavy duty carriers for safe and protected transport of your coils

The KLP® 4-way Coilcarrier was developed as a reusable carrier for transport of coils with a horizontal axis. It was designed in such a way that a forklift truck may enter from four directions.

The maximum dynamic capacity is 10 tons and coil diameters range from 1250 up to 1800 mm. Depending on the coil width and coil weight the carrier is constructed with two or three bars.

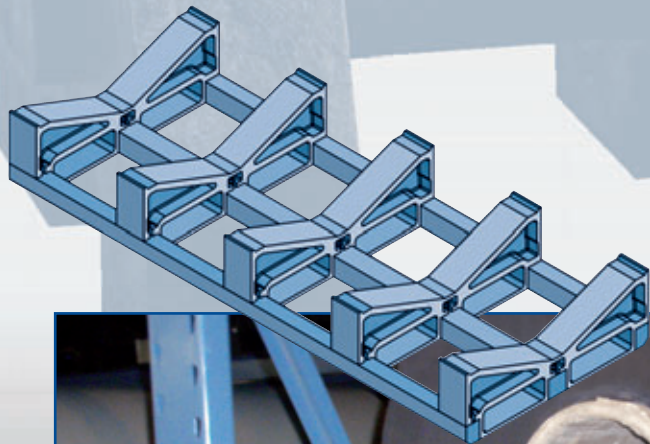
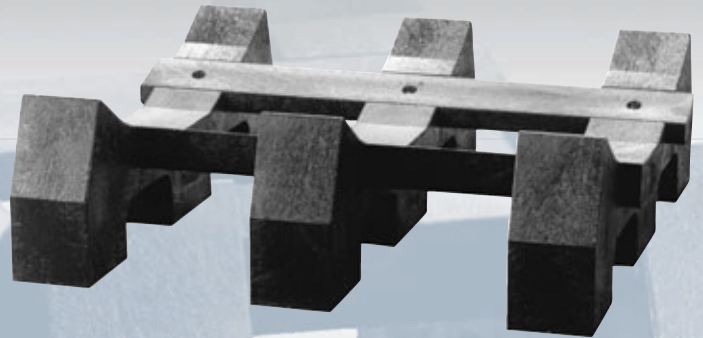

Custom made solutions

Lankhorst Mouldings can also design tailor made pallets for specific applications. Using existing or new moulds and steel reinforced beams we can create sustainable solutions.

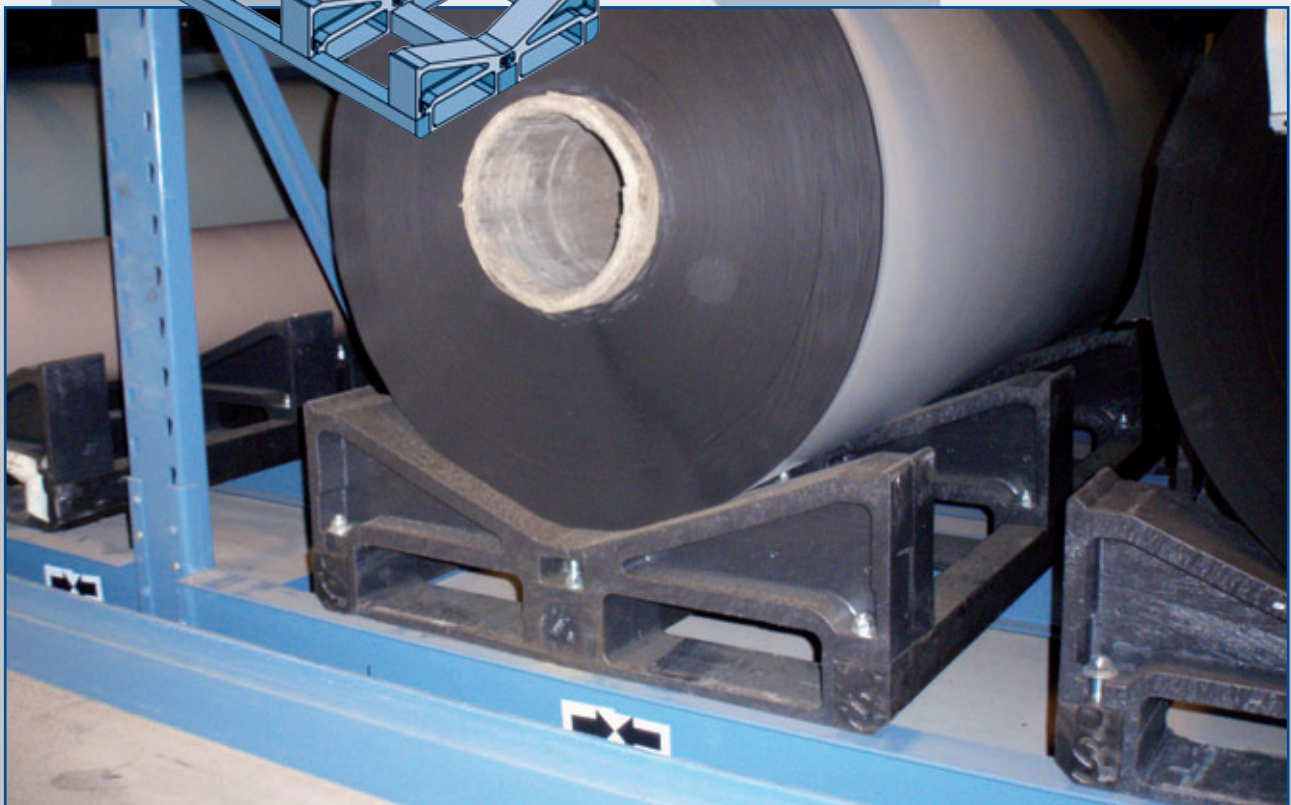

Lankhorst | *Mouldings bv*

Prinsengracht 2 - P.O. Box 203 - 8600 AE Sneek - The Netherlands

T +31 (0)515-487690 - F +31 (0)515-487622

I www.lankhorst-mouldings.com - E info@lankhorst-mouldings.com

